

# ESPACE



**ESPACE.  
GENEROUS CAPACITY.  
INCREDIBLE ADAPTABILITY.  
PANORAMIC VIEWS FROM EVERY SEAT.  
TRAVEL LIKE NEVER BEFORE.  
WITH ON-THE-ROAD FEATURES TO RIVAL  
A SALOON, ITS EXCEPTIONAL COMFORT  
DEMONSTRATES A SUPERIOR LEVEL OF QUALITY.  
ESPACE IS A CLEAR STYLE LEADER.**



Fluid lines and soft curves... Its glazed area, the largest on the market, gives you an exceptional level of light. Its unique personality is expressed in even the smallest detail: the chrome trim subtly underlines the front bumper... Espace or Grand Espace, Renault's flair for superb design is evident.

# ESPACE

REFINEMENT, VERSATILITY AND TECHNOLOGY.

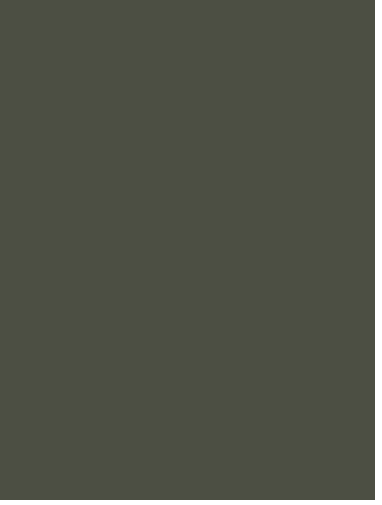

# ESPACE FOR THE SENSES

TRAVEL WITH PANORAMIC VIEWS.



The glazed area of Espace allows the scenery to unfold before you like a panoramic screen. The sunroof is completely adaptable, with four different positions for the electric sunblind. It floods the cabin with light and gives your passengers a breathtaking view of the sky above. In Espace, the show is never ending...

# ESPACE INTERIOR

ENJOY UNBEATABLE FREEDOM OF MOVEMENT.



Espace knows how to combine comfort and practicality. With the 'slide and lock' system, Espace can offer even greater versatility. Passengers in the back can select the perfect position for their seats. Whether you require space for a large number of passengers or for a large load, switching between 7, 6, 5, 4, 3 or even 2 seat configurations is simply child's play!



# PERFECT HARMONY

REFINED MATERIALS FOR OUTSTANDING COMFORT.

In Espace, the driver's seat is immensely comfortable and offers you a whole new perspective on driving: controls close at hand, a central display... Everything has been designed to make your life easier. The trims and the subtle, refined materials are elegant and offer striking contrasts for an unrivalled visual experience.





## EXPERT SAFETY

TRUST IN RENAULT'S EXPERTISE.

The new on-board technology allows you to identify and prevent risks no matter what the road conditions: automatic rain activated front windscreen wipers, automatic light sensor activated headlights and tyre pressure monitor.

In the event of an impact, Espace takes all possible steps to protect its occupants. This protection is provided by a reinforced body structure<sup>(1)</sup>, which is flexible to absorb impacts, as well as the Renault SRP (System for Restraint and Protection) comprising 8 airbags<sup>(2)</sup> and 3-point seatbelts with pretensioners and load limiters<sup>(3)</sup>.

The new on-board technology also helps you to maintain total control of your vehicle. Brake Assist coupled with ABS, Understeer Control plus ESP (Electronic Stability Programme)... all of these systems make Espace the benchmark in terms of active safety.



1



2



3

# POWERFUL PERFORMANCE

EXPERIENCE UNBEATABLE PERFORMANCE.

## **2.0 dCi engine:**

Available with particle filter in 150 Auto and 175 hp versions and without particle filter in 130 hp and 150 hp manual versions, this engine offers exceptional performance levels and fuel consumption. Economical, quiet and environmentally friendly, it offers increased torque across a wide operating range. It perfectly combines flexibility and responsiveness, for an incomparable driving experience.



# INTUITIVE RELATIONSHIP

TECHNOLOGY THAT FEELS NATURAL.

## Bluetooth® telephone system\*

Thanks to the Bluetooth® hands free mobile phone kit, you are free to hold a conversation while keeping your mobile wherever you want.



## 3D Satellite Navigation System with Bluetooth®\*

Espace has a top-of-the-range system, which is managed from the multimedia centre control. Located in the centre console, it allows all the multimedia functions to be controlled by the simple touch of a button: third generation ultra quick Renault navigation system, dash-mounted 6 CD audio system with MP3 facility and Bluetooth® hands free kit. Information is displayed on a 7" 16/9 colour screen.

\* To make and receive calls safely, it is recommended that you pull over and stop in an appropriate area



# TECHNICAL SPECIFICATIONS

	Petrol			Diesel				
	2.0 16V 140 Manual†	2.0T 16V 170 Manual	2.0T 16V 170 Auto	dCi 130 non FAP Manual	dCi 150 non FAP Manual	dCi 150 FAP Auto	dCi 175 FAP Manual	dCi 175 FAP Auto
Emission control type	Euro IV	Euro IV	Euro IV	Euro IV	Euro IV	Euro IV	Euro IV	Euro IV
Type approval numbers*	JK09A6	JK0AA6 / JK0AC6	JK0AAB / JK0ACB	JK02A6	JK0HA6 / JK0IA6	JK04AC / JK04CC	JK07AB / JK03	JK03AC / JK03CC
<b>ENGINE (Espace / Grand Espace)</b>								
Induction capacity	cc	1998	1998	1998	1995	1995	1995	1995
Bore x stroke	mm	82.7x93	82.7x93	82.7x93	84x90	84x90	84x90	84x90
Number of cylinders / valves		4 / 16	4 / 16	4 / 16	4 / 16	4 / 16	4 / 16	4 / 16
Compression ratio		9.8:1	9.8:1	9.8:1	16:01	16:01	16:01	16:01
Maximum power	kW ISO / hp DIN	100 / 140	125 / 170	125 / 170	96 / 130	110 / 150	110 / 150	127 / 175
	rpm	5500	5000	5000	4000	4000	4 000	3750
Maximum torque	Nm ISO / mkg DIN	191 / 20.0	270 / 26.0	270 / 26.0	320 / 33.3	340 / 33.3	340	360 / 36.7
	rpm	3750	3250	3250	2000	2000	2000	1750
Type of injection		Multipoint	Multipoint	Multipoint	Multipoint	Commonrail	Commonrail	Commonrail
<b>WEIGHT (Espace / Grand Espace)</b>								
Kerb vehicle weight	kg*	1665	1685 / 1735	1705 / 1765	1755	1775 / 1807	1780 / 1830	1780 / 1830
	lb*	3667	3711 / 3822	3888 / 3987	3866	3910 / 4009	3925 / 4035	3921 / 4031
Gross vehicle weight	kg*	2435	2475 / 2520	2490 / 2555	2537	2537 / 2587	2555 / 2610	2555 / 2610
	lb*	5363	5451 / 5551	5628 / 5727	5529	5628 / 5727	5634 / 5755	5628 / 5749
Maximum (driver only) towing weight (braked)	kg*	1800	2000	2000	2000	2000	2000	2000
	lb	3965	4405	4405	4405	4405	4405	4405
Maximum (driver only) towing weight (unbraked)	kg*	750	750	750	750	750	750	750
	lb	1652	1652	1652	1652	1652	1652	1652
<b>GEARBOX (Espace / Grand Espace)</b>								
Number of forward gears		6	6	5	6	6	6	6
Gearbox code		PK6 010	PK6 013	SU1 011	PK4 005	PK4 005	AJ0	PK4 005
SPEED (mph) at 1000 rpm (Espace / Grand Espace)	in 1 <sup>st</sup> gear*	4.4	4.6 / 4.7	6.0 / 6.1	5.1	5.1	5.5	5.1
	2 <sup>nd</sup> *†	8.2	8.7	9.6 / 9.7	9.4	9.5	9.6	9.5
	3 <sup>rd</sup> *†	11.6	12.3 / 12.4	14.8	14.3	14.5	14.5	14.8
	4 <sup>th</sup> *†	15.7	16.6	21.8 /21.9	19.4	19.6	19.8	19.6
	5 <sup>th</sup> *†	19.2	20.4	27.9 /28.0	24.4	23.4	26.8	24.6
<b>BRAKING SYSTEM (Espace / Grand Espace)</b>								
Front ventilated discs	mm	308	308	308	308	324	324	324
Rear drums / discs	mm	300	300	300	300	300	300	300
Suspension	front / rear	MacPherson with helical spring / Semi-rigid guided by two longitudinal arms						
<b>STEERING (Espace / Grand Espace)</b>								
Turning circle		11.0 / 11.3						
Tyres		225 / 60 R16	225 / 55 R17	225 / 55 R17	225 / 55 R17	225 / 55 R17	225 / 55 R17	225 / 55 R17
<b>CAPACITIES (Espace / Grand Espace)</b>								
Luggage capacity (max)	with 7 seats (litres)*				291 / 456			
	without rear seats (litres)*				2860 / 3050			
Fuel tank	litres / gallons				83 / 18.3			
<b>PERFORMANCE (Espace / Grand Espace)</b>								
0-100 kph / 0-62 mph	secs	12.5	9.7	10.6	13.5	10.6	12.4	9.8
Maximum speed	mph	115	127	122	114	121	117	123
	kph	185	205	197	184	194	188	204
Drag coefficient / area	CdA S / Cx	2.8 / 0.35						
<b>FUEL CONSUMPTION (Espace / Grand Espace)</b>								
Urban Cold	mpg*	22.2	22.4	20.0 / 19.6	31.7 / 32.1	31.7 / 32.1	26.6	33.2 / 32.5
	litres / 100km*	12.7	12.6	14.1 / 14.4	8.9 / 8.8	8.9 / 8.8	10.6	8.5 / 8.7
Extra Urban	mpg*	37.7	36.2	37.7 / 36.2	45.6 / 44.1	45.6 / 44.1	41.5	44.8 / 43.4
	litres / 100km*	7.5	7.8	7.5 / 7.8	6.2 / 6.4	6.2 / 6.4	6.8	6.3 / 6.5
Overall Cycle	mpg*	30.1	29.7	28.5 / 27.7	39.2	39.2	34.4	39.8 / 38.7
	litres / 100km*	9.4	9.5	9.9 / 10.2	7.2	7.2	8.2	7.1 / 7.3
CO <sub>2</sub> emissions	standard versions*	223	224	234 / 242	188 / 190	188 / 190	217	188 / 193
	with optional sunroof*	228	224	242	190	190	217	193

Where figures are marked with an asterisk, the first figure relates to Espace and the second figure relates to Grand Espace

† Available on Espace only

# ENGINES

## 2.0 16V 140

For an optimised torque of 191 Nm at 3,750 rpm. A flexible and economical engine.

## 2.0 TURBO 170

Develops a constant torque of 270 Nm across a range of between 3,250 rpm and 5,000 rpm.

## dCi 130, 150 AND 175

This engine is available with particulate filter in 150 Auto and 175 hp version and without particulate filter in 130 and 150 hp manual versions.

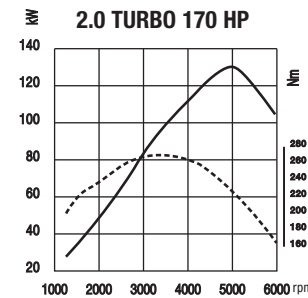
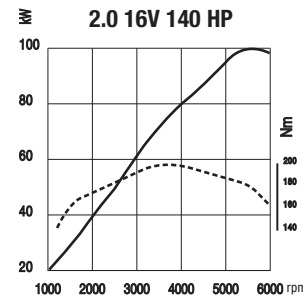

## dCi 130 NON FAP

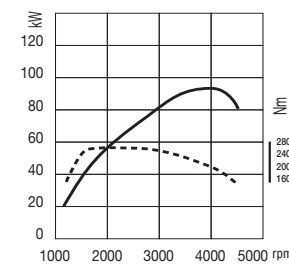

## dCi 150 HP NON FAP

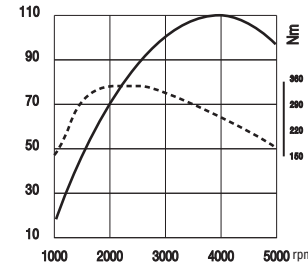

## dCi 175 FAP HP

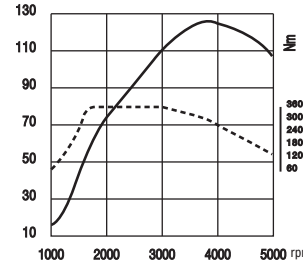

— Power  
- - - Torque



## 1. 5-SPEED OR 6-SPEED SEQUENTIAL PROACTIVE AUTOMATIC GEAR BOX

This gear box enhances driving pleasure with an automatic change-down function when the brake is pressed or ratio hold when rapidly depressed. Its appeal is increased by the sequential control, which also allows the driver to change gear.

## 6-SPEED MANUAL GEAR BOX

Its smoothness and fluidity ensure genuine driving pleasure. By shortening the gear ratio, the addition of a sixth gear enables you to better exploit the potential of the engine and to reduce fuel consumption and CO<sub>2</sub> emissions.

## COMFORT

### 1. ERGONOMIC DRIVING POSITION

The 16/9 screen (7" full colour display) of the 2D and 3D Satellite Navigation System (with Bluetooth®) is perfectly integrated into the dashboard.

### 2. CRUISE CONTROL / SPEED LIMITER WITH FINGERTIP CONTROL

The cruise control function can be used to select a constant speed for greater driving comfort. The speed limiter allows you to set a maximum speed which the vehicle will not exceed.

### 3. FRONT AND REAR PARKING PROXIMITY SENSORS

The system detects and warns you of any obstacles by means of a sequence of beeps, that get faster as you approach the object.

### 4. DOOR MIRRORS

Electric folding mirrors.

### 5. FRONT CLIMATE CONTROL

Displays the temperature and permits adjustment to the desired level.

### 6. INNOVATIVE AIR CONDITIONING SYSTEM

14 air outlets spread throughout the passenger compartment for controlled temperatures, calculated automatically by the humidity, sunshine, pollution and speed sensors.

### 7. HANDS FREE RENAULT CARD

You don't even have to take the card out of your pocket! Simply press the 'start' button on the dashboard to start the ignition. When you leave your vehicle, the doors lock automatically.



7



5



6



## MULTIMEDIA

### 1. AUDIO SYSTEMS

40W RDS radio MP3 CD player with fingertip control.

### 2. 2D SATELLITE NAVIGATION SYSTEM WITH BLUETOOTH®\*\*

Controlled from the CD player, it has 3 functions: navigation with TMC\*\*, dash-mounted mono CD audio system with MP3 facility and Bluetooth hands free kit.

### 3. 3D SATELLITE NAVIGATION SYSTEM WITH BLUETOOTH®\*\*

This system features 3 functions: third generation ultra quick 3D Renault navigation system with TMC\*\* (and 28 European Country maps), dash-mounted 6 CD audio system with MP3 facility and Bluetooth® hands free kit.

### 4. BLUETOOTH® HANDS FREE MOBILE PHONE KIT\*

Controlled from the steering wheel, you can make and receive calls safely. Your address book can be displayed on the screen.

### 5. DVD SCREENS

Relaxation for rear passengers who can enjoy long journeys watching DVDs, playing on a games console or even looking at photos.

\* To make and receive calls safely, it is recommended that you pull over and stop in an appropriate area.

\*\*TMC: Traffic Message Channel

## ADAPTABILITY

### FROM 2 TO 7 SEATS

For increased storage, you can remove or move 3, 4 or all 5 of the rear seats. This procedure is incredibly easy thanks to the seats that automatically click into place (fitted as standard).



## DRIVING EXPERIENCE



### 1. SEAT ADJUSTMENT

Front seats with electrical height and angle adjustment, with memory settings for the driver's seat.

### 2. CONTROL BUTTON FOR HEATED SEAT

### 3. FRONT 'CAPTAINS' CHAIRS'

With lumbar adjustment.

### 4. SLIDING SEATS

Thanks to the slide and lock system, the rear seats fold down easily and individually offering a wide range of seating options.



**OPENING TAILGATE WINDOW**  
Offers direct access to the boot, even if space is restricted.

## SAFETY

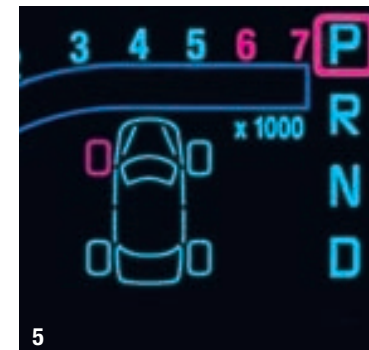
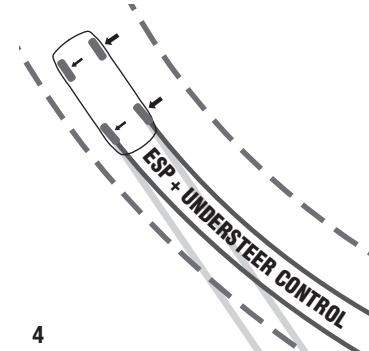

### 1. ABS

ABS (Anti-lock Braking System) and EBD (Electronic Brake Distribution), combined with Brake Assist help to maintain the vehicle's trajectory in the event of sudden braking.

### 2. XENON DIRECTIONAL HEADLIGHTS

These headlights offer an intense light that closely resembles daylight and hug the curve of the road, thus optimising anticipation and control.

### 3. AIRBAGS

Two frontal adaptive airbags for driver and front passenger.  
Two curtain airbags for head protection.  
Four front and rear lateral thorax airbags.

### 4. ESP (ELECTRONIC STABILITY PROGRAM)

With ASR Traction Control and CSV Understeer Control. Controls the stability of the vehicle in the event of avoidance manoeuvres, poor surface grip or irregular roadholding.

### 5. TYRE PRESSURE MONITOR

Displays tyre pressures and warns of any pressure failure, slow leak or puncture.

### 6. FRONT HEADRESTS

Height and tilt adjustable, to maximise comfort and security.

### 7. SEATBELTS WITH LOAD LIMITERS AND PRETENSIONERS IN THE FRONT

Hold the body in position with reduced loads in the event of an impact. Rear seat with 3-point seatbelt and load limiter.

### 8. REINFORCED STRUCTURE

Reinforced structure with programmed deformation zones in extremely high-yield steels, which can absorb greater energy in the event of a collision.

### 9. ISOFIX CHILD SEAT MOUNTING POINTS ON REAR SEATS

For installation of ISOFIX child safety seats. In addition to the standard two anchorage points at the base of the seat, there is an additional third point at the rear of the backrest to prevent tilting.



## STORAGE



**1. GLOVE BOX**



**2. SUPERIOR STORAGE SPACES**

Driver and front passenger dashboard storage.



**3. CUP HOLDER**

In centre console.



**4. CENTRE CONSOLE**

The centre console offers multiple spacious, ergonomic and practical storage options.



**5. SHELF AND CUP HOLDER**

**6. OPEN STORAGE POCKET**

In the front and rear door panels.

**7. CD STORAGE**

In the back of the vehicle.

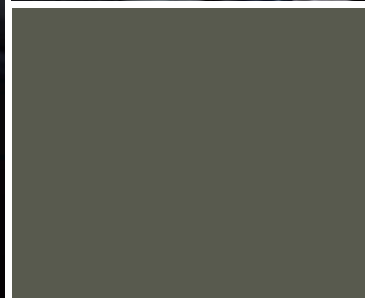

## ACCESSORIES



**1. ROOF BARS**

Made of aluminium, they are fitted on rails and are suitable for any type of roof box.



**2. RDSO TOWING BALL**

Can be removed in just a few seconds without the use of tools.



**3. TINTED WINDOWS**

Specifically designed to protect your privacy, filter UV rays and strengthen the resistance of the windows to breakage.



**4. TRENDY ANTI-SKID SLEEVES**

For driving in snow.



**5. CYCLE CARRIER**

Can accommodate up to three bicycles and still allows you to open the boot once the bicycles are unloaded.



**6. ALARM**

The anti-intrusion alarm protects your Espace and your belongings from theft.

**7. BOOT BOX**

The aluminium boot box with collapsible compartments offers 35 different combinations.



**8. FRIDGE (32 L)**

Fixed on rails, it allows you to keep food and / or drinks cold.

**9. CARPET**

Protects the floor against wear and moisture.

The range includes textile 3D Relief Evolution mats, which give a high-quality finish.

**10. SEAT COVER**

Protects and personalises the inside of your Espace.

**11. MULTI-FUNCTIONAL TUNEPPOINT**

Your USB key or iPod can be plugged in and controlled using the radio controls on the steering wheel. The jack allows you to connect any audio source.

**12. 17" 'SUPERTURISMO' ALLOY WHEELS**

The design and finish of these wheels give the vehicle a dynamic, sporty profile.

**13. 18" 'F1 SPORT' ALLOY WHEELS**

A signature model to give your vehicle a touch of class and sportiness.





## TEAM

The pleasure of total comfort. Espace Team features seven individual seats with the 'slide and lock' system, 'Arolla' dark carbon cloth upholstery (1), height adjustable driver's seat, air conditioning and front fog lights.



## DYNAMIQUE

The modern interior is both sporty and elegant. Available in dark carbon 'Plidiag' cloth / part 'Riviera' leather upholstery (2). Espace Dynamique is fully equipped with 17" alloy wheels, climate control, extra tinted windows, rear parking sensors, cruise control...



## DYNAMIQUE S

Dynamique S is available in part 'Riviera' leather / part Alcantara offering a very refined interior (1). It also features an impressive list of equipment, such as hands free keycard, automatic headlights and windscreen wipers, and multi-functional TunePoint (NC).



## INITIALE

Wooden trim, leather upholstery... the most luxurious Espace model. Elegance that goes hand in hand with high-precision technology. Very dark carbon perforated leather upholstery with dark carbon trim (1). Beige perforated leather upholstery with dark carbon / beige trim also available.

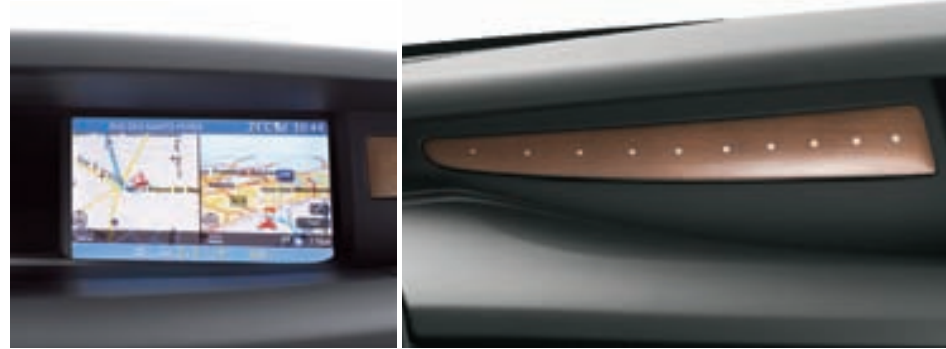

1

<p><b>Standard Equipment on Team:</b></p> <ul style="list-style-type: none"> <li>• ABS with EBD (Electronic Brake Distribution)</li> <li>• ESP (Electronic Stability Programme) with Traction Control and Understeer Control</li> <li>• Brake Assist</li> <li>• Anti-whiplash front headrests</li> <li>• Airbags - auto-adaptive for driver and front passenger</li> <li>• Airbags - front lateral</li> <li>• Airbags - front curtain</li> <li>• Airbag - front passenger deactivation</li> <li>• Driver's double seatbelt pretensioners</li> <li>• Headlights with 'See Me Home' function</li> <li>• Insurance approved (Thatcham category 2) engine immobiliser</li> </ul>	<ul style="list-style-type: none"> <li>• Height adjustable seatbelts and pretensioners (front and rear outer seats and 3-point rear seatbelts)</li> <li>• ISOFIX child seat mounting points - rear seats</li> <li>• Driver and front passenger seat belt reminder</li> <li>• R.A.I.D. (Renault Anti Intruder Device)</li> <li>• Remote control central locking with deadlocking and anti-drill door locks</li> <li>• Power-assisted steering</li> <li>• Door mirrors - body coloured electrically adjustable and heated</li> <li>• 4 x 30W radio MP3 CD reader with fingertip control</li> <li>• Electric front and rear windows with child lock</li> <li>• Steering wheel - height and reach adjustable</li> <li>• Keycard</li> </ul>	<ul style="list-style-type: none"> <li>• Double optic headlights</li> <li>• Trip computer - multi-functional</li> <li>• Automatic parking brake</li> <li>• 'Slide and lock' seating system</li> <li>• All manual versions feature 6-speed manual gearbox</li> <li>• Luggage compartment cover</li> <li>• Pre-telephone equipment (not fitted if Satellite Navigation system - full colour 3D map with Bluetooth® option)</li> <li>• Air conditioning with separate driver / front passenger controls</li> <li>• 7 individual seats</li> <li>• Driver and front passenger seats - height adjustable captain's chair with lumbar support</li> <li>• Front fog lights</li> </ul>	<p><b>TEAM</b></p>
<p><b>Standard Equipment on Dynamique:</b> <b>Plus Additional Standard Equipment to Team</b></p> <ul style="list-style-type: none"> <li>• 17" 'Tellus' alloy wheels</li> <li>• Chrome effect bumper strip with optional metallic paint</li> <li>• Extra tinted rear windows and tailgate</li> </ul>	<ul style="list-style-type: none"> <li>• Roof bars / rear roof spoiler</li> <li>• Climate control with separate driver / passenger controls (in lieu of air conditioning)</li> <li>• Leather upholstery - part-leather / part-cloth</li> <li>• Heat reflective windscreen</li> </ul>	<ul style="list-style-type: none"> <li>• Variable power-assisted steering (only on dCi 175)</li> <li>• Parking proximity sensors - rear</li> <li>• Insurance approved (Thatcham category 1) alarm system</li> <li>• Cruise control with speed limiter</li> </ul>	<p><b>DYNAMIQUE</b></p>
<p><b>Standard Equipment on Dynamique S:</b> <b>Plus Additional Standard Equipment to Dynamique</b></p> <ul style="list-style-type: none"> <li>• Part-leather / part-Alcantara upholstery</li> <li>• Multi-functional TunePoint (NC)*</li> <li>• Door mirrors - blue tinted, folding and heated</li> </ul>	<ul style="list-style-type: none"> <li>• Electric front and rear windows with anti-pinch, 'one-touch' controls</li> <li>• Keycard - hands free</li> <li>• Automatic headlights and windscreen wipers</li> </ul>	<ul style="list-style-type: none"> <li>• Variable power-assisted steering (only on dCi 175)</li> <li>• Sunblinds - side and rear</li> <li>• Carpet mats - rows 1, 2 and 3</li> </ul>	<p><b>DYNAMIQUE S</b></p>
<p><b>Standard Equipment on Initiale:</b> <b>Plus Additional Standard Equipment to Dynamique S</b></p> <ul style="list-style-type: none"> <li>• 17" 'Aida' alloy wheels</li> <li>• Beige leather upholstery - full (optional carbon leather free of charge)</li> <li>• 6 captains' chairs (replaces 7 individual seats)</li> </ul>	<ul style="list-style-type: none"> <li>• Climate control with separate row 2 passenger controls</li> <li>• Front seats electrically adjustable with memory settings for driver's seat and door mirrors</li> <li>• Electrochrome rear view mirror</li> <li>• Satellite navigation system - full colour 3D map with Bluetooth®</li> </ul>	<ul style="list-style-type: none"> <li>• 4 x 40W Cabasse 6 CD multi-changer with fingertip control, dash-mounted</li> <li>• Tyre pressure monitor</li> <li>• Variable power-assisted steering</li> <li>• Bi-Xenon headlights including headlight washers</li> </ul>	<p><b>INITIALE</b></p>

\* No cost option

## COLOURS

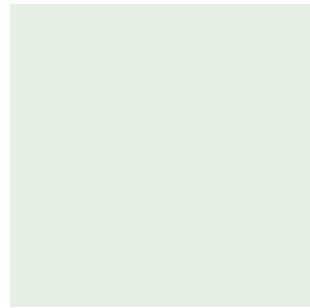

369 GLACIER WHITE (NM)



676 PEARL BLACK (MP)



472 TWILIGHT BLUE (MP)



B66 ECLIPSE (MI)



D69 MERCURY (MI)



K43 MOUNTAIN BLUE (MI)



A19 HESSIAN (MI)



NND VENETIAN RED (MI)



D19 TUSCAN BEIGE (MI)

TRIMS	MAIN BODY COLOURS								
	Glacier White 369 NM	Pearl Black 676 MP	Twilight Blue 472 MP	Eclipse B66 MI	Mercury D69 MI	Mountain Blue K43 MI	Hessian A19 MI	Venetian Red NND MI	Tuscan Beige D19 MI
TEAM	●	○	○	○	○	○	○	○	○
DYNAMIQUE	●	○	○	○	○	○	○	○	○
DYNAMIQUE S	●	○	○	○	○	○	○	○	○
INITIALE	●	○	○	○	○	○	○	○	○

● : Standard ○ : Optional - : Not available NM : Non metallic MI : Metallic Illusion MP : Metallic Pearlescent

## DIMENSIONS

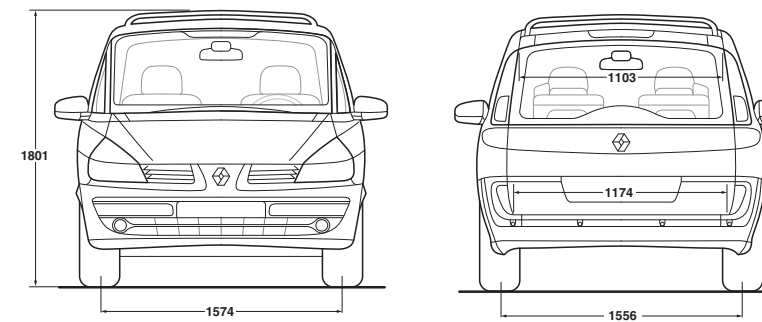
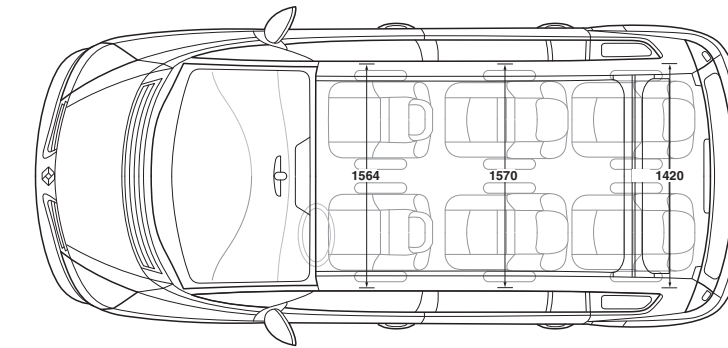
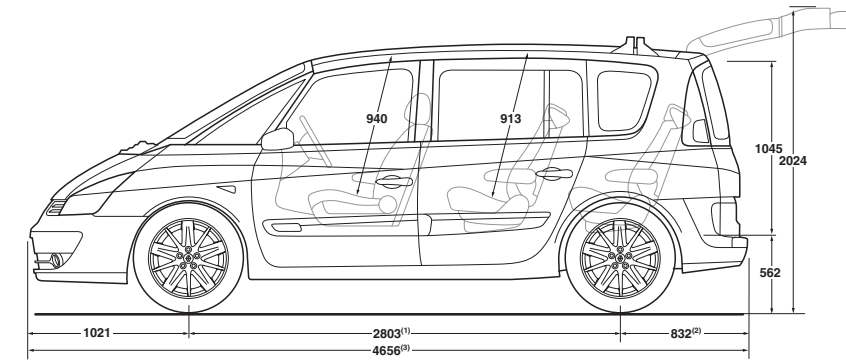

## WHEELS

1. 16" or 17" 'Primastella' wheel trims TEAM
2. 17" 'Novastella' alloy wheels TEAM (optional)
3. 17" 'Tellus' alloy wheels DYNAMIQUE AND DYNAMIQUE S
4. 17" 'Aida' alloy wheels INITIALE
5. 18" 'Pléiades' alloy wheels\* DYNAMIQUE, DYNAMIQUE S AND INITIALE (optional)

\* 18" WHEELS NOT CHAINABLE



## EQUIPMENT AND OPTIONS

	Team	Dynamique	Dynamique S	Initiale
<b>ACTIVE AND PASSIVE SAFETY FEATURES</b>				
ABS and Brake Assist with EBD (Electronic Brake Distribution)	●	●	●	●
ESP (Electronic Stability Programme) with CSV Understeer Control, ASR Traction Control and Brake Assist	●	●	●	●
Driver and front passenger airbag (with deactivation of front passenger airbag)	●	●	●	●
Auto-adaptive curtain airbags - rows 1 and 2	●	●	●	●
Lateral thorax airbags - row 1	●	●	●	●
Lateral thorax airbags - row 2	○ <sup>1</sup>	○ <sup>1</sup>	○	○
Audible seatbelt reminder, height adjustable seatbelts and double pretensioners for driver and passenger	●	●	●	●
Driver's double seatbelt pretensioners	●	●	●	●
Height adjustable seatbelts and pretensioners (front and rear outer seats and 3-point rear seatbelts)	●	●	●	●
Integrated 3-point seatbelts on all rear seats	●	●	●	●
Tyre pressure monitor	-	-	-	●
ISOFIX child seat mounting points on rear seats	●	●	●	●
Sleep safe child rear headrest (available to order as an accessory)	○	○	○	○
R.A.I.D. (Renault Anti Intruder Device) = Automatic door locking at >6mph	●	●	●	●
Third high-level brake light	●	●	●	●
Emergency spare wheel (185 / 60 R17C)	●	●	●	●
<b>VEHICLE SECURITY</b>				
Insurance approved (Thatcham category 2) engine immobiliser	●	●	●	●
Insurance approved (Thatcham Category 1) alarm	-	●	●	●
Deadlocking	●	●	●	●
Anti-theft wheelnuts for alloy wheels (included where alloys supplied)	○	●	●	●
<b>EXTERIOR FEATURES</b>				
<b>Styling</b>				
16" or 17" 'Primastella' wheel trims (depending on the engine)	●	-	-	-
17" 'Novastella' alloy wheels	○	-	-	-
17" 'Tellus' alloy wheels	-	●	●	-
17" 'Aida' alloy wheels	-	-	-	●
18" 'Pleiades' alloy wheels	-	○	○	○
Body coloured windscreen base	-	●	●	●
Metallic paint + all round paint: body coloured bumpers and side mouldings (with chrome bumper strip on Dynamique and above)	○	○	○	○
Integral body coloured roof bars / rear roof spoiler	○	●	●	●
Body coloured door mirrors	●	●	●	●
Body coloured exterior door handles	●	-	-	-
Satin chrome exterior door handles	-	●	●	●
<b>Functionality</b>				
Panoramic sunroof (fixed) with electric sunblind	○	○	-	-
Panoramic sunroof, electrically operated with electric sunblind	-	○	○	○
Extra-tinted rear windows and tailgate (from B pillar)	○	●	●	●
Tinted windscreen	●	-	-	-
Heat reflective windscreen	○ <sup>2</sup>	●	●	●
Heated rear windscreen	●	●	●	●
Opening tailgate window	-	○	○	○
Door mirrors - electrically operated and heated; blind spot eliminating mirror on driver's side	●	●	●	●
Door mirrors - electrically folding, with blue-tinted glare reduction glass	○ <sup>3/4</sup>	○	●	●
Integrated F1 style fuel filler cap	●	●	●	●
<b>Visibility and lighting</b>				
Twin element halogen headlights with manual headlight beam height adjustment	●	●	●	-
Bi-Xenon double optic headlights with automatic height adjustment and washers	-	○	○	●
Bi-Xenon directional headlights with washers / wipers and automatic beam height correction	-	-	-	○
Front fog lights	●	●	●	●
'See Me Home' headlights - dipped beam time delay	●	●	●	●
Automatic rain activated front windscreen wipers	-	-	●	●
Automatic light sensor activated headlights	-	-	●	●
Automatic day / night electrochrome rear view mirror	-	-	○	●
<b>IN-CAR ENTERTAINMENT AND COMMUNICATION SYSTEMS</b>				
Fingertip control audio system	●	●	●	●
4 x 30W single CD with MP3 facility	●	●	○	-
Multi-functional TunePoint	○ <sup>13</sup>	○ <sup>13</sup>	○ <sup>13</sup> (NC)*	-
Bluetooth Satellite Navigation with full colour display (2D) and 4 x 20W mono CD	○	○	○	-
Bluetooth Satellite Navigation system with full colour display (3D) and 4 x 40W Cabasse 6 CD multi-changer	○ <sup>6/12</sup>	○ <sup>8</sup>	○ <sup>8</sup>	●
Pre-telephone equipment*	●	●	●	●

	Team	Dynamique	Dynamique S	Initiale
<b>INTERIOR FEATURES</b>				
<b>Driving technology</b>				
Dashboard integrated audio system and fingertip control on steering wheel stalk	●	●	●	●
Keyless car with keycard		●	●	●
Keycard - hands free	○ <sup>10</sup>	○	●	○
Parking proximity sensor - rear	○	●	●	●
Parking proximity sensor - front	-	○	○	○
Automatic parking brake	●	●	● <sup>7</sup>	●
Power-assisted steering	●	● <sup>7</sup>	● <sup>7</sup>	-
Variable power-assisted steering	-	● <sup>7</sup>	● <sup>7</sup>	●
Trip computer	●	●	●	●
Cruise control with speed limiter on automatic versions	●	●	●	●
Cruise control with speed limiter on manual versions	○	●	●	●
<b>LUXURY, COMFORT AND CONVENIENCE</b>				
4-spoke leather-bound steering wheel and leather gearknob	●	●	●	●
Height and reach adjustable steering wheel	●	●	●	●
Leather gearstick gaiter	-	-	-	-
Air conditioning with separate front left / right controls	●	-	-	-
Climate control with separate driver / passenger controls and heat reflective windscreen	○	●	●	-
Climate control with separate row 2 passenger controls and rear sunblinds	-	○ <sup>4</sup>	○ <sup>4</sup>	●
6 integrated rear sunblinds (door windows, rear quarters and tailgate)	○	○	●	●
14 air outlets (rows 1, 2 and 3)	●	●	●	●
Electric front windows with anti-pinch sensors and one-touch control from driver's side; electric rear windows	●	●	-	-
Electric front and rear windows with anti-pinch sensors and one-touch controls	○ <sup>3/4/5</sup>	○ <sup>3/4/5</sup>	○	●
Auto closure of front and rear windows and sunroof (if fitted) when vehicle locked	○ <sup>3/4/5</sup>	○ <sup>3/4/5</sup>	●	●
Remote controlled doors, rear hatch and fuel flap	●	●	●	●
Front accessory socket / cigarette lighter, 2 integrated cup holders, movable ashtray	●	●	●	●
12V accessory power socket (centre console) accessible in row 2 or 3	●	●	●	●
Aircraft style folding trays for row 2 passengers, with integrated cup holders	●	●	●	●
Table with 2 integrated cup holders x 5 (fold-down seats in rows 2 and 3)	●	●	●	●
5 grab handles (silicon damped), and 2 vertical easy-access handles on middle pillar	●	●	●	●
Carpet mats rows 1 and 2	○	-	-	-
Carpet mat rows 1, 2 and 3	-	○	●	●
Boot space separation mat	○	○	○	○
<b>Seats</b>				
Slide and lock rail system	●	●	●	●
Driver and passenger seats with manual reclining adjustment, fully reclining position	●	●	●	-
Front captain's chair, height adjustment with adjustable / removable armrests and adjustable lumbar support on driver's seat	●	●	●	●
Carbon cloth upholstery	●	-	-	-
Part-leather sports style seats with carbon trim and red stitching	-	●	-	-
Part-leather / part-Alcantara sports style seats with carbon trim and red stitching	-	-	●	-
Full dark carbon leather and rear sunblinds	-	○	○	-
Full beige leather upholstery with beige interior panels and rear sunblinds (optional carbon leather free of charge)	-	-	-	●/○
Electrically adjustable front seats with memory settings on driver's side	-	○ <sup>5</sup>	○ <sup>5</sup>	●
Heated front seats	○	○	○	○
New generation front headrests - height and angle adjustable	●	●	●	●
Height adjustable integrated rear headrests	●	●	●	●
Rear seats with integrated 3-point seatbelts on sliding rails - all interchangeable, can fold into table, and removable	●	●	●	●
3 rear seats with ISOFIX child seat mounting points (in row 2)	●	●	●	●
7 seats	●	●	●	-
6 seats (6 captains' chairs - full leather, replacing 7 individual)	-	-	-	●
1 extra seat	-	-	-	○
Armrests - 6 rear	-	○	○	●
<b>OPTION PACKS</b>				
Safety Pack (sleep safe rear headrests x 2, lateral airbags for row 2, 6 rear sunblinds)	○	○	-	-
Comfort Pack Plus (hands free keycard with electric folding door mirrors, panoramic sunroof, multi-functional TunePoint)	-	○	-	-
Convenience Pack (climate control with separate row 2 passenger controls, 6 rear sunblinds, opening tailgate window)	-	○	-	-
● = Standard   ○ = Optional   - = Not available   *No pre-telephone equipment with 3D Satellite Navigation system				

(1) Option must be ordered with 6 rear sunblinds.   (2) Option included with 'Dual climate control with front door controls and heat reflecting windscreen' option.   (3) Option included with the hands free Renault card option.
(4) Option included in the rear climate control + 6 sunblinds option.   (5) 'Electrically adjustable front seats' option includes programmable memory settings for door mirrors and anti-pinch rear windows.
(6) Includes anti-pinch rear windows.   (7) Variable power-assisted steering on dCi 175. All other engines = power-assisted steering.   (8) Row 2 central light panel replaced by 2 courtesy outer light panels where optional panoramic sunroof fitted.   (9) Only available with manual gear box versions.   (10) Hands free Renault card must be ordered with climate control (Team only).   (11) Bluetooth Satellite Navigation System must be ordered with climate control and cruise control.   (12) Bluetooth Satellite Navigation System must be ordered with climate control and cruise control.   (13) Not compatible with 2D, 3D satellite navigation.

\*NC = No cost option, to be specified when ordering

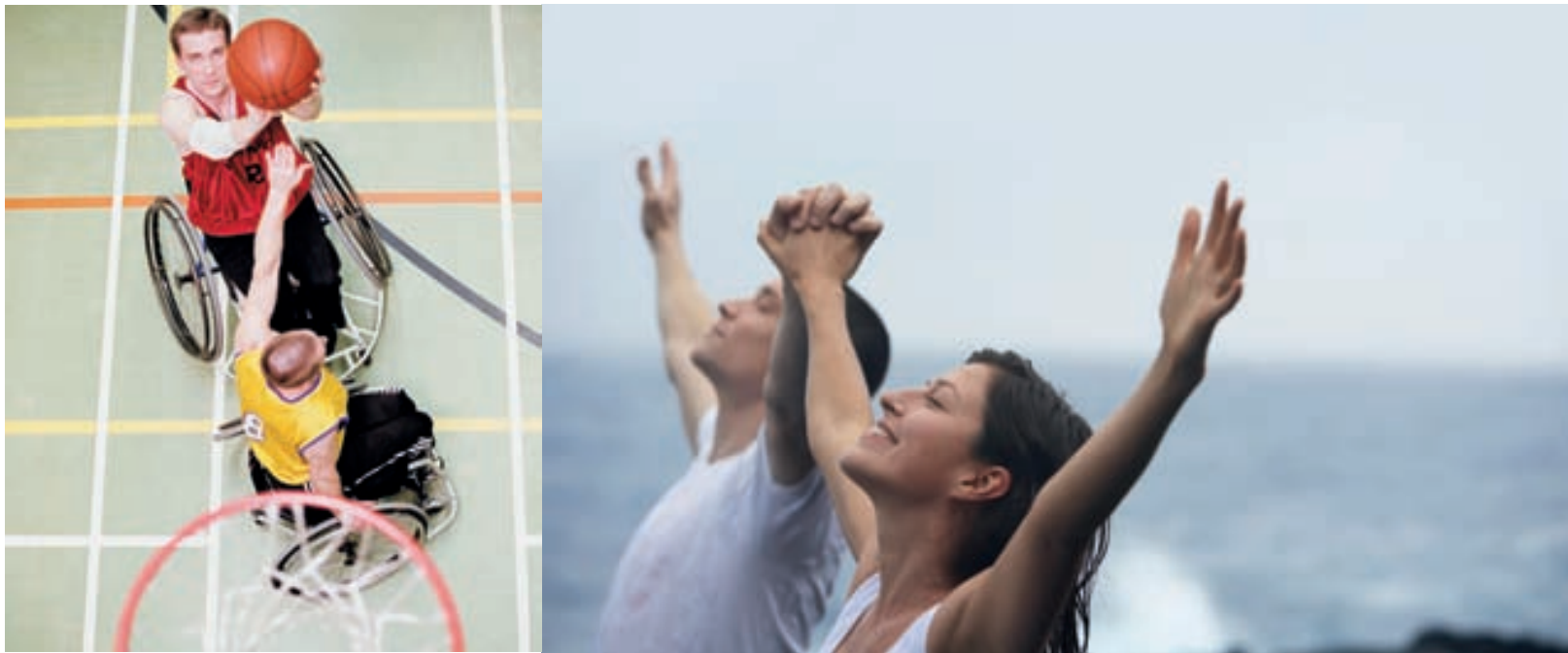

## RENAULT MOBILITY

As the market leader in safety, with ten vehicles in the range scoring the maximum five stars in the Euro NCAP safety tests, Renault offers an extensive range of models through the Motability scheme. With our advanced design technology, all of our models can be cost effectively adapted by Motability Accredited Specialists to meet the particular needs of a disabled driver or user. At your nearest Motability Accredited Renault Dealer, you will find a commitment to personal service, facilities for easy access including ramps and wide doors, plus expert assistance from Motability specialists. If you'd like more information about these special services or about a specific vehicle adaptation, put us to the test right now by calling Renault Corporate on 0800 387 626, contacting [motability@renault.co.uk](mailto:motability@renault.co.uk) or visiting [www.motability.renault.co.uk](http://www.motability.renault.co.uk).



# WHO BETTER THAN RENAULT TO SERVICE YOUR RENAULT?



Your new Renault is covered by a 3-year warranty package – the first 2 years of unlimited mileage Renault manufacturer warranty, followed by a further year of cover up to 60,000<sup>†</sup> miles. This requires full servicing history according to Renault UK approved current standards. Paintwork is also guaranteed for 3 years while the anti-corrosion warranty runs for 12 years (Master anti-corrosion warranty runs for 6 years). In addition, the Renault Assistance plan ensures prompt help in the UK and Northern Ireland for manufacturer defects for 24 months (36 months for light commercial vehicles, or cars registered before 1<sup>st</sup> September 2006).

## FINANCE OPTIONS

There are a wide variety of ways in which the purchase of a new car can be financed. Renault Finance offers all of them, so whether you're a fleet buyer or a private buyer, Renault Finance is ideally placed to tell you which plan or combination of plans best suits your needs and circumstances.

## SERVICE INTERVALS

All models

- **18,000 miles / 2 years**

Except:

- Petrol 1.2 TCe 100 engine
- Renaultsport versions
- Clio, Modus & Kangoo dCi 68 & 86 engines
- Laguna Petrol 2.0 16V

- **12,000 miles / 2 years**

- New Mégane dCi 86

- **12,500 miles / 2 years**

- Kangoo Petrol 1.6 16V
- Espace Petrol 2.0 16V
- Espace all Diesel engines
- Master all engines

- **18,000 miles / 1 year**

- Kangoo Petrol 1.6 8V
- Laguna Petrol Turbo & V6
- Laguna dCi 180
- Espace Petrol 2.0 Turbo
- Koleos all engines

- **12,000 miles / 1 year**

## ENGINES WITH OIL CONTROL SYSTEM (OCS)

- 1.2 TCe 100 / 1.4 TCe 130 / 2.0 TCe 180

- 1.6 VVT 128
- All dCi 86, 90, 100, 106, 110, 115, 120, 130, 150, 160, 175 & 180 (except Koleos)
- V6 dCi 235

OCS monitors driving conditions that directly affect the quality of your engine oil, protecting your diesel or petrol engine from premature wear. OCS allows Renault to extend service intervals for certain Diesel engines from 12,000 miles to 18,000 miles providing reduced maintenance costs.

## RENAULT FOR YOU

Renault For You is a collection of products designed for making motoring easy:

- Extended Warranty for New Vehicles allows you to extend your Renault Warranty up to 5 years or 100,000 miles.
- Extended Warranty for Used Vehicles.
- Renault Assistance Added Cover provides you with the services of the AA for certain problems that are not covered by Renault Assistance: punctures, incorrect (or lack of) fuel, keys lost, stolen or locked inside the vehicle, road traffic accidents, incidents involving caravans and trailers.
- MOT Test Warranty offers you protection should your car fail its MOT Test. For further information about these products, ask your Renault Dealer or simply log on to [www.renault.co.uk](http://www.renault.co.uk) and click on 'Owner Services', where you can purchase all of them securely online.

## RENAULT ACCIDENT SUPPORT LINE – 0800 085 8005

The Renault Accident Support Line (RASL) is a dedicated service from Renault for all Renault drivers and their families, no matter what car they drive. This service is available at no cost to you, regardless of fault. RASL will deal with every aspect of your claim, from ensuring you are recovered to a Renault Approved Accident Repair Centre to dealing with all insurance companies giving you total convenience and peace of mind.

**0800 085 8005** is the only number you need so please programme it into your phone and make sure that in the event of an accident you call us first and we will take care of everything.

### RASL will:

- Arrange recovery of your vehicle from the scene of the accident to a Renault Approved Accident Repair Centre
- Organise the repairs at a Renault Approved Accident Repair Centre using only Renault Original Parts

- Deal with all insurance companies, both yours and the other parties'
- Provide a like for like replacement vehicle if the accident is not your fault
- Pursue the at fault party for all associated costs if the accident is not your fault
- Use the same paint as during manufacture
- Provide a 5 year repair guarantee on paint and repairs
- Ensure you do not have to pay a policy excess if the accident is not your fault
- Provide the same service for your family free of charge regardless if their car is a Renault or not
- Ensure that yours and your passengers' safety are guaranteed and your five star NCAP rating will not be compromised

## RENAULT NETWORK SERVICES

No-one is better placed than Renault to maintain, fit and repair your Renault, fast. The Renault Minute (maintenance and repair with no appointment necessary) and Renault Rapide Bodycare (bumper scuffs, dings and dents, windscreen, stone chips and interior repairs...) services deliver the highest level of repair and maintenance and offer a full year's guarantee on Original Renault Parts. And don't forget to have a look at our wide range of additional equipment and accessories!

## RENAULT INSURANCE

A car as well designed as your Renault deserves an insurance policy to match. Renault Insurance has been specifically created to provide superb protection for you and your car.\* In addition to a very competitive premium, Renault Insurance also includes: a free 24-hour accident recovery programme; Renault Genuine parts fitted in Renault Accident Repair Centres, protecting your 12 year anticorrosion warranty; repairs guaranteed for 3 years; a courtesy car for the duration of any repairs – subject to availability when you use an approved repairer; payment by instalments – subject to status.

Lines open 8am – 8pm weekdays, 9am – 2pm Saturdays. Calls may be recorded. Terms and Conditions apply. All quotes are based on individual circumstance and subject to insurers underwriting criteria. Renault insurance is arranged and administered by Equity Insurance Brokers Limited, which is authorised and regulated by the Financial Services Authority. Registered Office: Library House, New Road, Brentwood, Essex, CM14 4GD. Registered in England No. 258414

<sup>†</sup> 100,000 miles for Koleos, Laguna and Espace.

\* Note: this does not apply to vans or Renaultsport cars.

## CUSTOMER SERVICES

Renault knows the value of communicating with its customers and we have established effective ways to keep in touch with you. If after speaking to your local Renault dealership you are not completely satisfied, please contact the Renault UK Customer Service Department on **0800 072 3372** (Mon-Fri 8.30am to 5.30pm).

You can also visit our website [www.renault.co.uk](http://www.renault.co.uk) Or write to us at: **Renault UK Ltd, The Rivers Office Park, Denham Way, Maple Cross, Rickmansworth, Hertfordshire, WD3 9YS.**

# ESPACE



(Enter Renault's world at [www.renault.tv](http://www.renault.tv))

Although every effort has been made to ensure that the information contained within this brochure is as accurate and up to date as possible, Renault U.K. reserves the right to modify its models without notice including their characteristics, specifications, equipment and accessories. Brochures inevitably become out of date or inaccurate in some respects, in that such characteristics, equipment, specifications or accessories may be changed after the publication date given below and can differ from the descriptions given. It is therefore necessary to check with your Renault Dealer before purchasing any product that the characteristics, specifications, equipment or accessories of the vehicle on order are as advertised. Publication date October 2009.